CHAPTER 3

COLUMN FORMULAS

GENERAL CONSIDERATIONS

Columns are structural members subjected to direct compression. All columns can be grouped into the following three classes:

1. *Compression blocks* are so short (with a slenderness ratio—that is, unsupported length divided by the least radius of gyration of the member—below 30) that bending is not potentially occurring.
2. Columns so slender that bending under load is a given are termed *long columns* and are defined by Euler's theory.
3. Intermediate-length columns, often used in structural practice, are called *short columns*.

Long and short columns usually fail by buckling when their *critical load* is reached. Long columns are analyzed using Euler's column formula, namely,

$$P_{cr} = \frac{n\pi^2 EI}{l^2} = \frac{n\pi^2 EA}{(l/r)^2}$$

In this formula, the coefficient n accounts for end conditions. When the column is pivoted at both ends, $n = 1$; when one end is fixed and the other end is rounded, $n = 2$; when both ends are fixed, $n = 4$; and when one end is fixed and the other is free, $n = 0.25$. The slenderness ratio separating long columns from short columns depends on the modulus of elasticity and the yield strength of the column material. When Euler's formula results in $(P_{cr}/A) > S_y$, strength instead of buckling causes failure, and the column ceases to be long. In quick estimating numbers, this *critical slenderness ratio* falls between 120 and 150. Table 3.1 gives additional column data based on Euler's formula.

TABLE 3.1 Strength of Round-Ended Columns According to Euler's Formula*

Material†	Cast iron	Wrought iron	Low-carbon steel	Medium-carbon steel
Ultimate compressive strength, lb/in ²	107,000	53,400	62,600	89,000
Allowable compressive stress, lb/in ² (maximum)	7,100	15,400	17,000	20,000
Modulus of elasticity	14,200,000	28,400,000	30,600,000	31,300,000
Factor of safety	8	5	5	5
Smallest I allowable at worst section, in ⁴	Pl^2	Pl^2	Pl^2	Pl^2
Limit of ratio, $l/r >$	17,500,000	56,000,000	60,300,000	61,700,000
	50.0	60.6	59.4	55.6
	14.4	17.5	17.2	16.0
Rectangle $\left(r = b\sqrt{1/12} \right), ll/b >$	12.5	15.2	14.9	13.9
Circle $\left(r = 1/4d \right), ll/d >$				
Circular ring of small thickness $\left(r = d\sqrt{1/8} \right), ll/d >$	17.6	21.4	21.1	19.7

* (P = allowable load, lb; l = length of column, in; b = smallest dimension of a rectangular section, in; d = diameter of a circular section, in; r = least radius of gyration of section.)

† To convert to SI units, use: lb/in² × 6.894 = kPa; in⁴ × (25.4)⁴ = mm⁴.

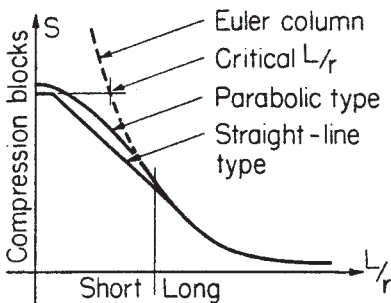

FIGURE 3.1 L/r plot for columns.

SHORT COLUMNS

Stress in short columns can be considered to be partly due to compression and partly due to bending. Empirical, rational expressions for column stress are, in general, based on the assumption that the permissible stress must be reduced below that which could be permitted were it due to compression only. The manner in which this reduction is made determines the type of equation and the slenderness ratio beyond which the equation does not apply. Figure 3.1 shows the curves for this situation. Typical column formulas are given in Table 3.2.

ECCENTRIC LOADS ON COLUMNS

When short blocks are loaded eccentrically in compression or in tension, that is, not through the center of gravity (cg), a combination of axial and bending stress results. The maximum unit stress S_M is the algebraic sum of these two unit stresses.

TABLE 3.2 Typical Short-Column Formulas

Formula	Material	Code	Slenderness ratio
$S_w = 17,000 - 0.485 \left(\frac{l}{r}\right)^2$	Carbon steels	AISC	$\frac{l}{r} < 120$
$S_w = 16,000 - 70 \left(\frac{l}{r}\right)$	Carbon steels	Chicago	$\frac{l}{r} < 120$
$S_w = 15,000 - 50 \left(\frac{l}{r}\right)$	Carbon steels	AREA	$\frac{l}{r} < 150$
$S_w = 19,000 - 100 \left(\frac{l}{r}\right)$	Carbon steels	Am. Br. Co.	$60 < \frac{l}{r} < 120$
${}^{\dagger}S_{cr} = 135,000 - \frac{15.9}{c} \left(\frac{l}{r}\right)^2$	Alloy-steel tubing	ANC	$\frac{l}{\sqrt{cr}} < 65$
$S_w = 9,000 - 40 \left(\frac{l}{r}\right)$	Cast iron	NYC	$\frac{l}{r} < 70$

TABLE 3.2 Typical Short-Column Formulas (Continued)

Formula	Material	Code	Slenderness ratio
$^{\dagger}S_{cr} = 34,500 - \frac{245}{\sqrt{c}} \left(\frac{l}{r} \right)$	2017ST aluminum	ANC	$\frac{l}{r} < 94$
$^{\dagger}S_{cr} = 5,000 - \frac{0.5}{c} \left(\frac{l}{r} \right)^2$	Spruce	ANC	$\frac{l}{r} < 72$
$^{\dagger}S_{cr} = S_y \left[1 - \frac{S_y}{4n\pi^2 E} \left(\frac{l}{r} \right)^2 \right]$	Steels	Johnson	$\frac{l}{r} < \sqrt{\frac{2n\pi^2 E}{S_y}}$
$^{\ddagger}S_{cr} = \frac{S_y}{1 + \frac{ec}{r^2} \sec \left(\frac{l}{r} \sqrt{\frac{P}{4AE}} \right)}$	Steels	Secant	$\frac{l}{r} < \text{critical}$

$^{\dagger}S_{cr}$ = theoretical maximum; c = end fixity coefficient; $c = 2$, both ends pivoted; $c = 2.86$, one pivoted, other fixed; $c = 4$, both ends fixed; $c = 1$ one fixed, one free.

‡ is initial eccentricity at which load is applied to center of column cross section.

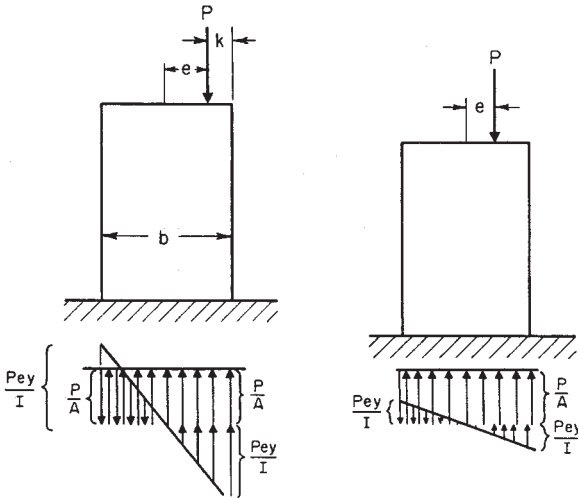

FIGURE 3.2 Load plot for columns.

In Fig. 3.2, a load, P , acts in a line of symmetry at the distance e from cg; r = radius of gyration. The unit stresses are (1) S_c , due to P , as if it acted through cg, and (2) S_b , due to the bending moment of P acting with a leverage of e about cg. Thus, unit stress, S , at any point y is

$$\begin{aligned}
 S &= S_c \pm S_b \\
 &= (P/A) \pm Pe y/I \\
 &= S_c(1 \pm ey/r^2)
 \end{aligned}$$

y is positive for points on the same side of cg as P , and negative on the opposite side. For a *rectangular cross section* of

width b , the maximum stress, $S_M = S_c(1 + 6e/b)$. When P is outside the middle third of width b and is a compressive load, tensile stresses occur.

For a *circular cross section* of diameter d , $S_M = S_c(1 + 8e/d)$. The stress due to the weight of the solid modifies these relations.

Note that in these formulas e is measured from the gravity axis and gives tension when e is greater than one-sixth the width (measured in the same direction as e), for rectangular sections, and when greater than one-eighth the diameter, for solid circular sections.

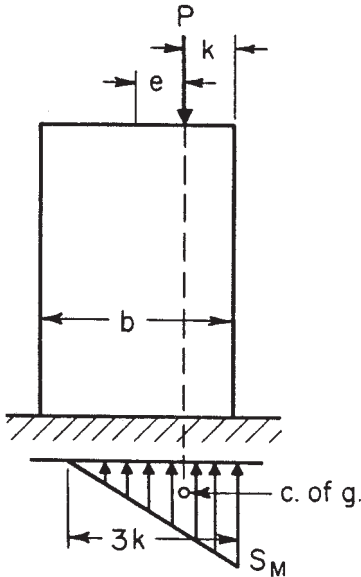

FIGURE 3.3 Load plot for columns.

If, as in certain classes of masonry construction, the material cannot withstand tensile stress and, thus, no tension can occur, the center of moments (Fig. 3.3) is taken at the center of stress. For a rectangular section, P acts at distance k from the nearest edge. Length under compression = $3k$, and $S_M = \sqrt[2]{3P/hk}$. For a circular section, $S_M = [0.372 + 0.056(k/r)]P/k\sqrt{rk}$, where r = radius and k = distance of P from circumference. For a circular ring, S = average compressive stress on cross section produced by P ; e = eccentricity of P ; z = length of diameter under compression (Fig. 3.4). Values of z/r and of the ratio of S_{max} to average S are given in Tables 3.3 and 3.4.

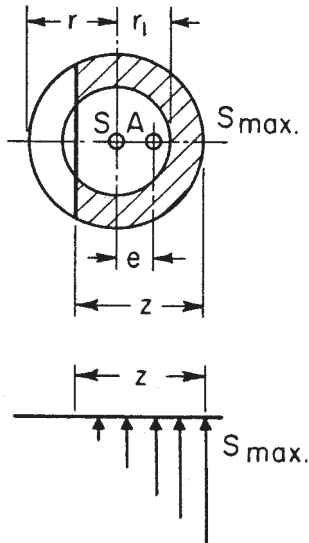

FIGURE 3.4 Circular column load plot.

TABLE 3.3 Values of the Ratio z/r
(See Fig. 3.5)

$\frac{e}{r}$	$\frac{r_1}{r}$										$\frac{e}{r}$	
	0.0	0.5	0.6	0.7	0.8	0.9	1.0					
0.25	2.00											0.25
0.30	1.82											0.30
0.35	1.66	1.89	1.98									0.35
0.40	1.51	1.75	1.84	1.93								0.40
0.45	1.37	1.61	1.71	1.81	1.90							0.45
0.50	1.23	1.46	1.56	1.66	1.78	1.89					2.00	0.50
0.55	1.10	1.29	1.39	1.50	1.62	1.74	1.87					0.55
0.60	0.97	1.12	1.21	1.32	1.45	1.58	1.71					0.60
0.65	0.84	0.94	1.02	1.13	1.25	1.40	1.54					0.65
0.70	0.72	0.75	0.82	0.93	1.05	1.20	1.35					0.70
0.75	0.59	0.60	0.64	0.72	0.85	0.99	1.15					0.75
0.80	0.47	0.47	0.48	0.52	0.61	0.77	0.94					0.80
0.85	0.35	0.35	0.35	0.36	0.42	0.55	0.72					0.85
0.90	0.24	0.24	0.24	0.24	0.24	0.32	0.49					0.90
0.95	0.12	0.12	0.12	0.12	0.12	0.12	0.25					0.95

TABLE 3.4 Values of the Ratio S_{\max}/S_{avg}
 (In determining S average, use load P divided by total area of cross section)

$\frac{e}{r}$	$\frac{r_1}{r}$									$\frac{e}{r}$
	0.0	0.5	0.6	0.7	0.8	0.9	1.0		1.0	
0.00	1.00	1.00	1.00	1.00	1.00	1.00	1.00	1.00	1.00	0.00
0.05	1.20	1.16	1.15	1.13	1.12	1.11	1.10	1.10	1.10	0.05
0.10	1.40	1.32	1.29	1.27	1.24	1.22	1.20	1.20	1.20	0.10
0.15	1.60	1.48	1.44	1.40	1.37	1.33	1.30	1.30	1.30	0.15
0.20	1.80	1.64	1.59	1.54	1.49	1.44	1.40	1.40	1.40	0.20
0.25	2.00	1.80	1.73	1.67	1.61	1.55	1.50	1.50	1.50	0.25
0.30	2.23	1.96	1.88	1.81	1.73	1.66	1.60	1.60	1.60	0.30
0.35	2.48	2.12	2.04	1.94	1.85	1.77	1.70	1.70	1.70	0.35
0.40	2.76	2.29	2.20	2.07	1.98	1.88	1.80	1.80	1.80	0.40
0.45	3.11	2.51	2.39	2.23	2.10	1.99	1.90	1.90	1.90	0.45

The *kern* is the area around the center of gravity of a cross section within which any load applied produces stress of only one sign throughout the entire cross section. Outside the kern, a load produces stresses of different sign. Figure 3.5 shows kerns (shaded) for various sections.

For a *circular ring*, the radius of the kern $r = D[1+(d/D)^2]/8$.

For a *hollow square* (H and $h =$ lengths of outer and inner sides), the kern is a square similar to Fig. 3.5a, where

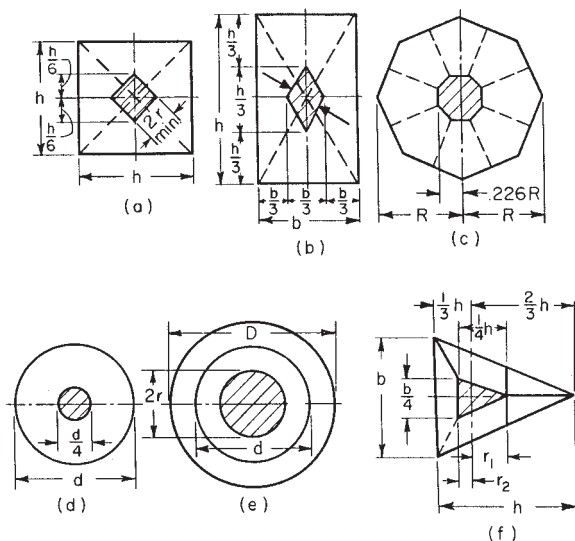

FIGURE 3.5 Column characteristics.

$$r_{\min} = \frac{H}{6} \frac{1}{\sqrt{2}} \left[1 + \left(\frac{h}{H} \right)^2 \right] = 0.1179H \left[1 + \left(\frac{h}{H} \right)^2 \right]$$

For a *hollow octagon*, R_a and R_i = radii of circles circumscribing the outer and inner sides; thickness of wall = $0.9239(R_a - R_i)$; and the kern is an octagon similar to Fig. 3.5c, where $0.2256R$ becomes $0.2256R_a[1 + (R_i/R_a)^2]$.

COLUMN BASE PLATE DESIGN

Base plates are usually used to distribute column loads over a large enough area of supporting concrete construction that the design bearing strength of the concrete is not exceeded. The factored load, P_u , is considered to be uniformly distributed under a base plate.

The nominal bearing strength f_p kip/in² or ksi (MPa) of the concrete is given by

$$f_p = 0.85f'_c \sqrt{\frac{A_1}{A_2}} \quad \text{and} \quad \sqrt{\frac{A_2}{A_1}} \leq 2$$

where f'_c = specified compressive strength of concrete, ksi (MPa)

A_1 = area of the base plate, in² (mm²)

A_2 = area of the supporting concrete that is geometrically similar to and concentric with the loaded area, in² (mm²)

In most cases, the bearing strength, f_p is $0.85f'_c$, when the concrete support is slightly larger than the base plate or $1.7f'_c$, when the support is a spread footing, pile cap, or mat

foundation. Therefore, the required area of a base plate for a factored load P_u is

$$A_1 = \frac{P_u}{\phi_c 0.85 f'_c}$$

where ϕ_c is the strength reduction factor = 0.6. For a wide-flange column, A_1 should not be less than $b_f d$, where b_f is the flange width, in (mm), and d is the depth of column, in (mm).

The length N , in (mm), of a rectangular base plate for a wide-flange column may be taken in the direction of d as

$$N = \sqrt{A_1} + \Delta > d \quad \text{or} \quad \Delta = 0.5(0.95d - 0.80b_f)$$

The width B , in (mm), parallel to the flanges, then, is

$$B = \frac{A_1}{N}$$

The thickness of the base plate t_p , in (mm), is the largest of the values given by the equations that follow:

$$t_p = m \sqrt{\frac{2P_u}{0.9F_y BN}}$$

$$t_p = n \sqrt{\frac{2P_u}{0.9F_y BN}}$$

$$t_p = \lambda n' \sqrt{\frac{2P_u}{0.9F_y BN}}$$

where m = projection of base plate beyond the flange and parallel to the web, in (mm)

$$= (N - 0.95d)/2$$

n = projection of base plate beyond the edges of the flange and perpendicular to the web, in (mm)

$$= (B - 0.80b_f)/2$$

$$n' = \sqrt{(db_f)}/4$$

$$\lambda = (2\sqrt{X})/[1 + \sqrt{(1 - X)}] \leq 1.0$$

$$X = [(4 db_f)/(d + b_f)^2][Pu/(\phi \times 0.85f'_c A_1)]$$

AMERICAN INSTITUTE OF STEEL CONSTRUCTION ALLOWABLE-STRESS DESIGN APPROACH

The lowest columns of a structure usually are supported on a concrete foundation. The area, in square inches (square millimeters), required is found from:

$$A = \frac{P}{F_p}$$

where P is the load, kip (N) and F_p is the allowable bearing pressure on support, ksi (MPa).

The allowable pressure depends on strength of concrete in the foundation and relative sizes of base plate and concrete support area. If the base plate occupies the full area of the support, $F_p = 0.35f'_c$, where f'_c is the 28-day compressive strength of the concrete. If the base plate covers less than the full area, $F_p = 0.35f'_c \sqrt{A_2/A_1} \leq 0.70f'_c$, where A_1 is the base-plate area ($B \times N$), and A_2 is the full area of the concrete support.

Eccentricity of loading or presence of bending moment at the column base increases the pressure on some parts of the base plate and decreases it on other parts. To compute these effects, the base plate may be assumed completely rigid so that the pressure variation on the concrete is linear.

Plate thickness may be determined by treating projections m and n of the base plate beyond the column as cantilevers.

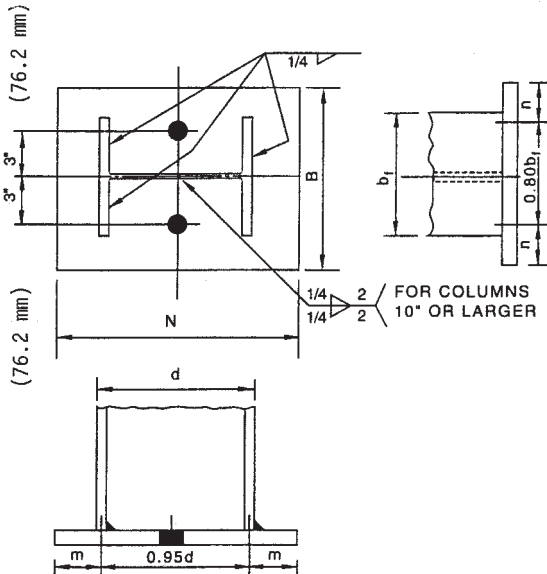

FIGURE 3.6 Column welded to a base plate.

The cantilever dimensions m and n are usually defined as shown in Fig. 3.6. (If the base plate is small, the area of the base plate inside the column profile should be treated as a beam.) Yield-line analysis shows that an equivalent cantilever dimension n' can be defined as $n' = 1/4\sqrt{db_f}$, and the required base plate thickness t_p can be calculated from

$$t_p = 2l \sqrt{\frac{f_p}{F_y}}$$

where $l = \max(m, n, n')$, in (mm)

$$f_p = P/(BN) \leq F_p, \text{ ksi (MPa)}$$

F_y = yield strength of base plate, ksi (MPa)

P = column axial load, kip (N)

For columns subjected only to direct load, the welds of column to base plate, as shown in Fig. 3.6, are required principally for withstanding erection stresses. For columns subjected to uplift, the welds must be proportioned to resist the forces.

COMPOSITE COLUMNS

The AISC load-and-resistance factor design (LRFD) specification for structural steel buildings contains provisions for design of concrete-encased compression members. It sets the following requirements for qualification as a composite column: The cross-sectional area of the steel core—shapes,

pipe, or tubing—should be at least 4 percent of the total composite area. The concrete should be reinforced with longitudinal load-carrying bars, continuous at framed levels, and lateral ties and other longitudinal bars to restrain the concrete; all should have at least $1\frac{1}{2}$ in (38.1 mm) of clear concrete cover. The cross-sectional area of transverse and longitudinal reinforcement should be at least 0.007 in^2 (4.5 mm^2) per in (mm) of bar spacing. Spacing of ties should not exceed two-thirds of the smallest dimension of the composite section. Strength of the concrete f'_c should be between 3 and 8 ksi (20.7 and 55.2 MPa) for normal-weight concrete and at least 4 ksi (27.6 MPa) for light-weight concrete. Specified minimum yield stress F_y of steel core and reinforcement should not exceed 60 ksi (414 MPa). Wall thickness of steel pipe or tubing filled with concrete should be at least $b\sqrt{F_y/3E}$ or $D\sqrt{F_y/8E}$, where b is the width of the face of a rectangular section, D is the outside diameter of a circular section, and E is the elastic modulus of the steel.

The AISC LRFD specification gives the design strength of an axially loaded composite column as ϕP_n , where $\phi = 0.85$ and P_n is determined from

$$\phi P_n = 0.85A_s F_{cr}$$

For $\lambda_c \leq 1.5$

$$F_{cr} = 0.658\lambda_c^2 F_{my}$$

For $\lambda_c > 1.5$

$$F_{cr} = \frac{0.877}{\lambda_c^2} F_{my}$$

where $\lambda_c = (KL/r_m \pi) \sqrt{F_{my}/E_m}$

KL = effective length of column in (mm)

A_s = gross area of steel core in² (mm²)

$F_{my} = F_y + c_1 F_{yr}(A_r/A_s) + c_2 f'_c(A_c/A_s)$

$E_m = E + c_3 E_c(A_c/A_s)$

r_m = radius of gyration of steel core, in ≤ 0.3 of the overall thickness of the composite cross section in the plane of buckling for steel shapes

A_c = cross-sectional area of concrete in² (mm²)

A_r = area of longitudinal reinforcement in² (mm²)

E_c = elastic modulus of concrete ksi (MPa)

F_{yr} = specified minimum yield stress of longitudinal reinforcement, ksi (MPa)

For concrete-filled pipe and tubing, $c_1 = 1.0$, $c_2 = 0.85$, and $c_3 = 0.4$. For concrete-encased shapes, $c_1 = 0.7$, $c_2 = 0.6$, and $c_3 = 0.2$.

When the steel core consists of two or more steel shapes, they should be tied together with lacing, tie plates, or batten plates to prevent buckling of individual shapes before the concrete attains $0.75 f'_c$.

The portion of the required strength of axially loaded encased composite columns resisted by concrete should be developed by direct bearing at connections or shear connectors can be used to transfer into the concrete the load applied directly to the steel column. For direct bearing, the design strength of the concrete is $1.7 \phi_c f'_c A_b$, where $\phi_c = 0.65$ and A_b = loaded area, in² (mm²). Certain restrictions apply.

ELASTIC FLEXURAL BUCKLING OF COLUMNS

Elastic buckling is a state of lateral instability that occurs while the material is stressed below the yield point. It is of special importance in structures with slender members. Euler's formula for pin-ended columns (Fig. 3.7) gives valid results for the critical buckling load, kip (N). This formula is, with L/r as the slenderness ratio of the column,

$$P = \frac{\pi^2 EA}{(L/r)^2}$$

where E = modulus of elasticity of the column material, psi (Mpa)

A = column cross-sectional area, in² (mm²)

r = radius of gyration of the column, in (mm)

Figure 3.8 shows some ideal end conditions for slender columns and corresponding critical buckling loads. Elastic critical buckling loads may be obtained for all cases by substituting an effective length KL for the length L of the pinned column, giving

$$P = \frac{\pi^2 EA}{(KL/r)^2}$$

In some cases of columns with open sections, such as a cruciform section, the controlling buckling mode may be one of twisting instead of lateral deformation. If the warping rigidity of the section is negligible, *torsional buckling* in a pin-ended column occurs at an axial load of

$$P = \frac{GJA}{I_p}$$

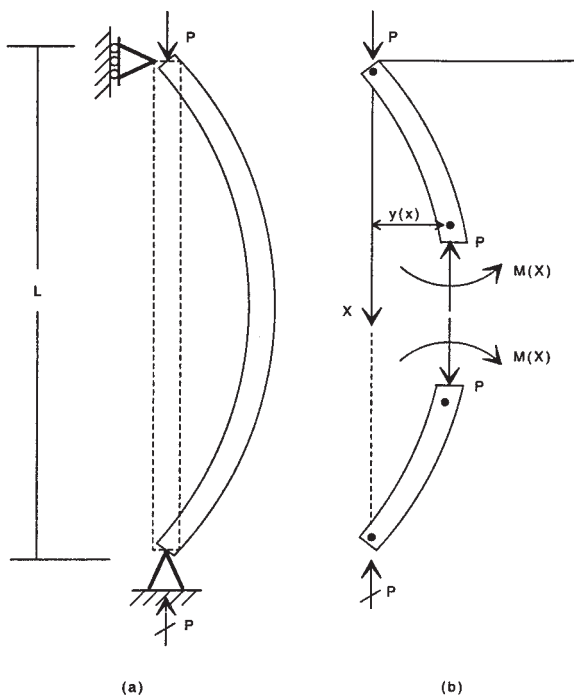

FIGURE 3.7 (a) Buckling of a pin-ended column under axial load. (b) Internal forces hold the column in equilibrium.

where G = shear modulus of elasticity

J = torsional constant

A = cross-sectional area

I_p = polar moment of inertia = $I_x + I_y$

COLUMN FORMULAS





Type of column	Effective length	Critical buckling load
	L	$\frac{\pi^2 EI}{L^2}$
	$\frac{L}{2}$	$\frac{4\pi^2 EI}{L^2}$
	$\approx 0.7L$	$\approx \frac{2\pi^2 EI}{L^2}$
	$2L$	$\frac{\pi^2 EI}{4L^2}$

FIGURE 3.8 Buckling formulas for columns.

If the section possesses a significant amount of warping rigidity, the axial buckling load is increased to

$$P = \frac{A}{I_p} \left(GJ + \frac{\pi^2 EC_w}{L^2} \right)$$

where C_w is the warping constant, a function of cross-sectional shape and dimensions.

ALLOWABLE DESIGN LOADS FOR ALUMINUM COLUMNS

Euler's equation is used for long aluminum columns, and depending on the material, either Johnson's parabolic or straight-line equation is used for short columns. These equations for aluminum follow:

Euler's equation:

$$F_e = \frac{c\pi^2 E}{(L/\rho)^2}$$

Johnson's generalized equation:

$$F_c = F_{ce} \left[1 - K \left(\frac{(L/\rho)}{\pi \sqrt{\frac{cE}{F_{ce}}}} \right)^n \right]$$

The value of n , which determines whether the short column formula is the straight-line or parabolic type, is selected

from Table 3.5. The transition from the long to the short column range is given by

$$\left(\frac{L}{\rho}\right)_{cr} = \pi \sqrt{\frac{kcE}{F_{ce}}}$$

where F_e = allowable column compressive stress

F_{ce} = column yield stress and is given as a function of F_{cy} (compressive yield stress)

L = length of column

ρ = radius of gyration of column

E = modulus of elasticity—noted on nomograms

c = column-end fixity from Fig. 3.9

n, K, k = constants from Table 3.5

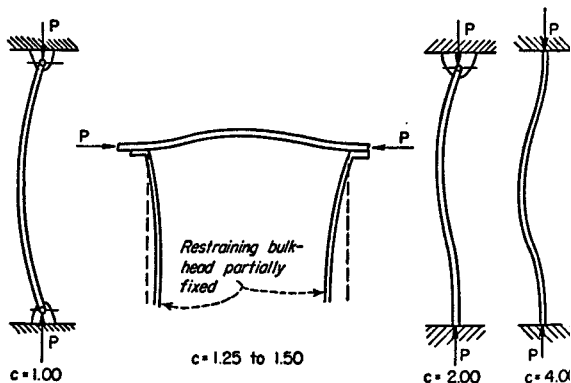

FIGURE 3.9 Values of c , column-end fixity, for determining the critical L/ρ ratio of different loading conditions.

TABLE 3.5 Material Constants for Common Aluminum Alloys

Material	Average F_{cy}		Values F_{ce}				K	k	n	Type Johnson equation
	psi	MPa	psi	MPa	MPa					
14S-T4	34,000	234.4	39,800	274.4	0.385	3.00	1.0	Straight line		
24S-T3 and T4	40,000	275.8	48,000	330.9	0.385	3.00	1.0	Straight line		
61S-T6	35,000	241.3	41,100	283.4	0.385	3.00	1.0	Straight line		
14S-T6	57,000	393.0	61,300	422.7	0.250	2.00	2.0	Squared parabolic		
75S-T6	69,000	475.8	74,200	511.6	0.250	2.00	2.0	Squared parabolic		

Ref: ANC-5.

ULTIMATE STRENGTH DESIGN CONCRETE COLUMNS

At ultimate strength P_u , kip (N), columns should be capable of sustaining loads as given by the American Concrete Institute *required strength* equations in Chap. 5, "Concrete Formulas" at actual eccentricities. P_u , may not exceed ϕP_n , where ϕ is the capacity reduction factor and P_n , kip (N), is the column ultimate strength. If P_o , kip (N), is the column ultimate strength with zero eccentricity of load, then

$$P_o = 0.85 f'_c (A_g - A_{st}) + f_y A_{st}$$

where f_y = yield strength of reinforcing steel, ksi (MPa)

f'_c = 28-day compressive strength of concrete,
ksi (MPa)

A_g = gross area of column, in² (mm²)

A_{st} = area of steel reinforcement, in² (mm²)

For members with spiral reinforcement then, for axial loads only,

$$P_u \leq 0.85\phi P_o$$

For members with tie reinforcement, for axial loads only,

$$P_u \leq 0.80\phi P_o$$

Eccentricities are measured from the plastic centroid. This is the centroid of the resistance to load computed for the assumptions that the concrete is stressed uniformly to $0.85 f'_c$ and the steel is stressed uniformly to f_y .

The axial-load capacity P_u kip (N), of short, rectangular members subject to axial load and bending may be determined from

$$P_u = \phi(0.85 f'_c b a + A'_s f_y - A_s f_s)$$

$$P_u e' = \phi \left[0.85 f'_c b a \left(d - \frac{a}{2} \right) + A'_s f_y (d - d') \right]$$

where e' = eccentricity, in (mm), of axial load at end of member with respect to centroid of tensile reinforcement, calculated by conventional methods of frame analysis

b = width of compression face, in (mm)

a = depth of equivalent rectangular compressive-stress distribution, in (mm)

A'_s = area of compressive reinforcement, in² (mm²)

A_s = area of tension reinforcement, in² (mm²)

d = distance from extreme compression surface to centroid of tensile reinforcement, in (mm)

d' = distance from extreme compression surface to centroid of compression reinforcement, in (mm)

f_s = tensile stress in steel, ksi (MPa)

The two preceding equations assume that a does not exceed the column depth, that reinforcement is in one or two faces parallel to axis of bending, and that reinforcement in any face is located at about the same distance from the axis of bending. Whether the compression steel actually yields at ultimate strength, as assumed in these and the following equations, can be verified by strain compatibility calculations. That is, when the concrete crushes, the strain in the compression steel, $0.003 (c - d')/c$, must be larger than the strain when the steel starts to yield, f_y/E_s . In this

case, c is the distance, in (mm), from the extreme compression surface to the neutral axis and E_s is the modulus of elasticity of the steel, ksi (MPa).

The load P_b for balanced conditions can be computed from the preceding P_u equation with $f_s = f_y$ and

$$\begin{aligned} a &= a_b \\ &= \beta_1 c_b \\ &= \frac{87,000 \beta_1 d}{87,000 + f_y} \end{aligned}$$

The balanced moment, in. · kip (k · Nm), can be obtained from

$$\begin{aligned} M_b &= P_b e_b \\ &= \phi \left[0.85 f'_c b a_b \left(d - d'' - \frac{a_b}{2} \right) \right. \\ &\quad \left. + A'_s f_y (d - d' - d'') + A_s f_y d'' \right] \end{aligned}$$

where e_b is the eccentricity, in (mm), of the axial load with respect to the plastic centroid and d'' is the distance, in (mm), from plastic centroid to centroid of tension reinforcement.

When P_u is less than P_b or the eccentricity, e , is greater than e_b , tension governs. In that case, for unequal tension and compression reinforcement, the ultimate strength is

$$\begin{aligned} P_u &= 0.85 f'_c b d \phi \left\{ \rho' m' - \rho m + \left(1 - \frac{e'}{d} \right) \right. \\ &\quad \left. + \sqrt{\left(1 - \frac{e'}{d} \right)^2 + 2 \left[(\rho m - \rho' m') \frac{e'}{d} + \rho' m' \left(1 - \frac{d'}{d} \right) \right]} \right\} \end{aligned}$$

where

$$m = f'_y / 0.85f'_c$$

$$m' = m - 1$$

$$\rho = A_s / bd$$

$$\rho' = A'_s / bd$$

Special Cases of Reinforcement

For symmetrical reinforcement in two faces, the preceding P_u equation becomes

$$P_u = 0.85 f'_c b d \phi \left\{ -\rho + 1 - \frac{e'}{d} + \sqrt{\left(1 - \frac{e'}{d}\right)^2 + 2\rho \left[m' \left(1 - \frac{d'}{d}\right) + \frac{e'}{d} \right]} \right\}$$

Column Strength When Compression Governs

For no compression reinforcement, the P_u equation becomes

$$P_u = 0.85 f'_c b d \phi \left[-\rho m + 1 - \frac{e'}{d} + \sqrt{\left(1 - \frac{e'}{d}\right)^2 + 2 \frac{e' \rho m}{d}} \right]$$

When P_u is greater than P_b , or e is less than e_b , compression governs. In that case, the ultimate strength is approximately

$$P_u = P_o - (P_o - P_b) \frac{M_u}{M_b}$$

$$P_u = \frac{P_o}{1 + (P_o/P_b - 1)(e/e_b)}$$

where M_u is the moment capacity under combined axial load and bending, in kip (k Nm) and P_o is the axial-load capacity, kip (N), of member when concentrically loaded, as given.

For symmetrical reinforcement in single layers, the ultimate strength when compression governs in a column with depth, h , may be computed from

$$P_u = \phi \left(\frac{A'_s f_y}{e/d - d' + 0.5} + \frac{b h f'_c}{3 h e / d^2 + 1.18} \right)$$

Circular Columns

Ultimate strength of short, circular members with bars in a circle may be determined from the following equations:

When tension controls,

$$P_u = 0.85 f'_c D^2 \phi \left[\sqrt{\left(\frac{0.85e}{D} - 0.38 \right)^2 + \frac{\rho_l m D_s}{2.5D}} - \left(\frac{0.85e}{D} - 0.38 \right) \right]$$

where D = overall diameter of section, in (mm)

D_s = diameter of circle through reinforcement, in (mm)

$$\rho_t = A_{st}/A_g$$

When compression governs,

$$P_u = \phi \left[\frac{A_{st}f_v}{3e/D_s + 1} + \frac{A_g f'_c}{9.6D_e/(0.8D + 0.67D_s)^2 + 1.18} \right]$$

The eccentricity for the balanced condition is given approximately by

$$e_b = (0.24 - 0.39 \rho_t m)D$$

Short Columns

Ultimate strength of short, square members with depth, h , and with bars in a circle may be computed from the following equations:

When tension controls,

$$P_u = 0.85bhf'_c\phi \left[\sqrt{\left(\frac{e}{h} - 0.5\right)^2 + 0.67 \frac{D_s}{h} \rho_t m} - \left(\frac{e}{h} - 0.5\right) \right]$$

When compression governs,

$$P_u = \phi \left[\frac{A_{st} f_y}{3e/D_s + 1} + \frac{A_g f'_c}{12he/(h + 0.67D_s)^2 + 1.18} \right]$$

Slender Columns

When the slenderness of a column has to be taken into account, the eccentricity should be determined from $e = M_c/P_u$, where M_c is the magnified moment.